

Two Post Parking Lift Hydro-Park 1132

- 3200kg capacity for different demands
- Middle post sharing feature saves cost and space
- Dynamic mechanical locks as “all the way” anti-falling device hold the platform in place
- Galvanized and corrugated platform guarantee safety and long lifetime
- Anti-slip corrugated deck protects both vehicle and driver from possible slip and damage but still high-heel shoe friendly
- Dual hydraulic lifting cylinders direct drive
- The pole with piston is chroming to anti-corrode to ensure its long using life
- Individual hydraulic power pack and control panel
- Self-standing and self-support structure
- Symmetrical designed column
- Special designed control arm for operator to control the lift without getting under the platform
- Synchronization chain assuring the lifting platform balance
- Electric key switch for security and safety
- A unique “LOCK DOWN” button for platform sitting on locking tab to protect cylinder
- Automatic shut-off if operator releases the key switch
- Manual lock release available in case electricity failure
- Platform can be stopped at different heights to fit for various vehicles and ceiling heights
- Hydraulic overloading protection

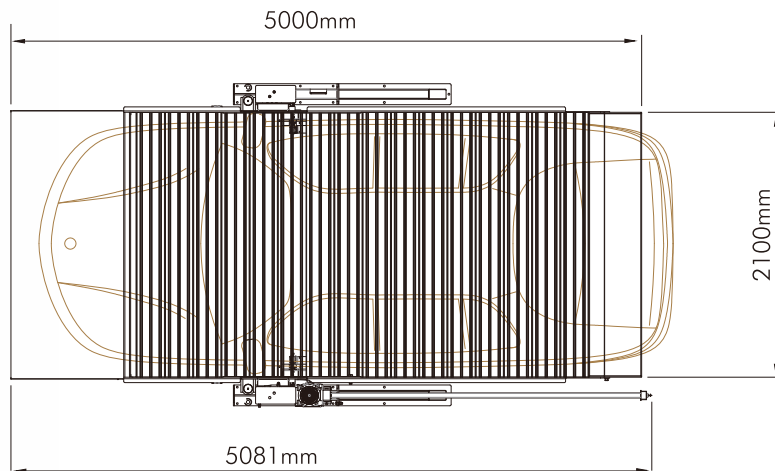

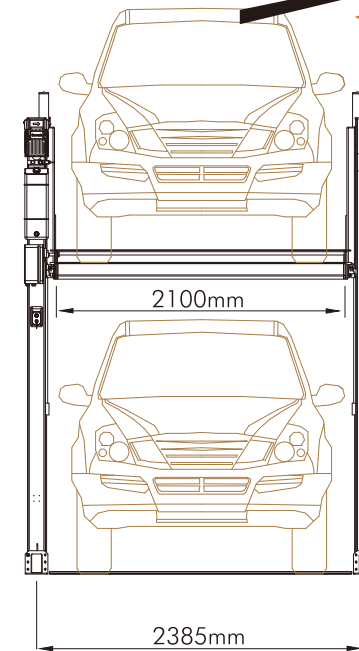
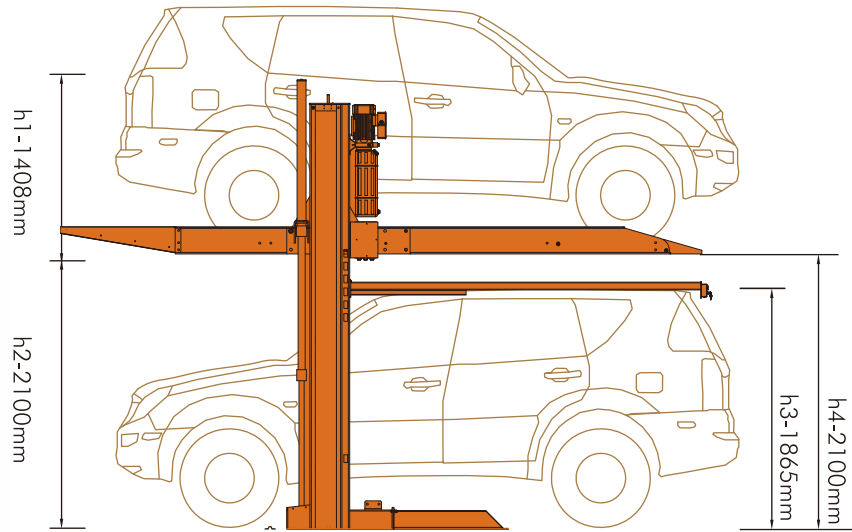

Lifting capacity	3200kg/7000lbs
Lifting height	2100mm/83inches
Usable platform width	2100mm/83inches
Power Unit	3Kw hydraulic pump
Available voltage of power supply	100V-450V, 1 or 3 Phase, 50/60Hz
Operation mode	Key switch
Operation voltage	24V
Safety lock	Dynamic anti-falling lock
Lock release	Electric auto release
Rising/descending speed	<40s
Finishing	Powder coating



Hydro-Park 1127
Two Post Parking Lift
Lima, Peru

Certified by



MOTRIX
AUTO EQUIPMENT

Two Post Parking Lift Hydro-Park 1127

- 2700kg capacity for most types of vehicles
- Self-standing and self-support structure
- Symmetrical designed column
- Middle post sharing feature saves cost and space
- Galvanized and corrugated platform guarantee safety and long lifetime
- Anti-slip corrugated deck protects both vehicle and driver from possible slip and damage but still high-heel shoe friendly
- Single hydraulic lifting cylinder with chain as driven system makes movement faster and more smooth
- Individual hydraulic power pack and 24V safety control panel
- Synchronization chain assuring the lifting platform balance
- Electric key switch for security and safety
- Unique "LOCK DOWN" button for platform sitting on locking tab to protect cylinder
- Automatic shut-off once operator releases the key switch
- Dynamic mechanical locks as anti-falling device hold the platform in place all the way
- Manual lock release available in case electricity failure
- Platform can be stopped at different heights to fit for various vehicles and ceiling heights
- Photocell sensor detection could stop operation if any vehicle under platform
- Hydraulic overloading protection





Key switch for easy operation with emergency stop button and lock down button

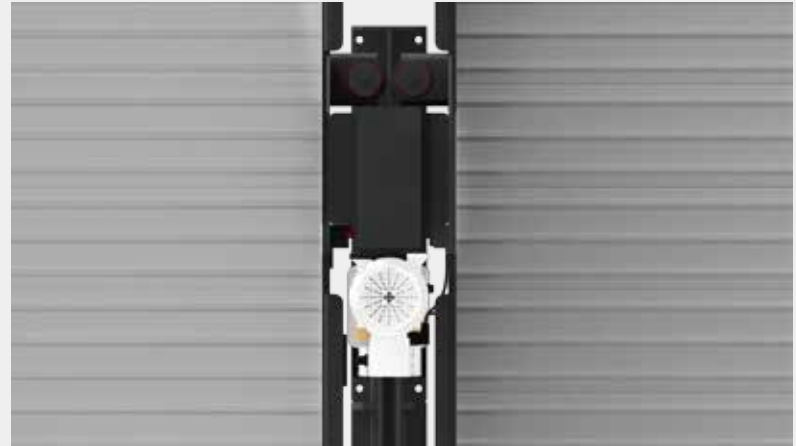

Advanced sharing post feature saves land space and cost



Individual power pack and control system for each unit makes operation more convenient



Advanced mechanical anti-falling lock device

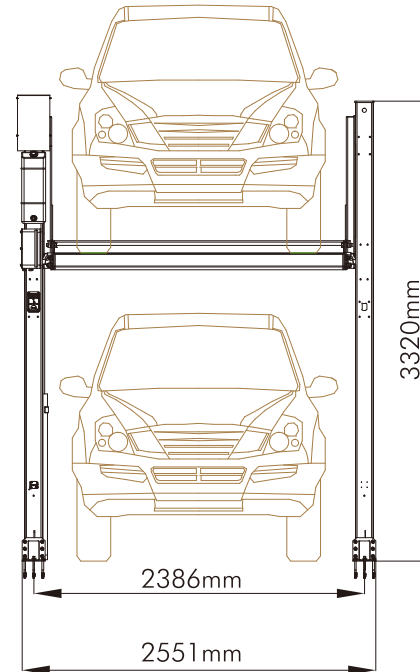
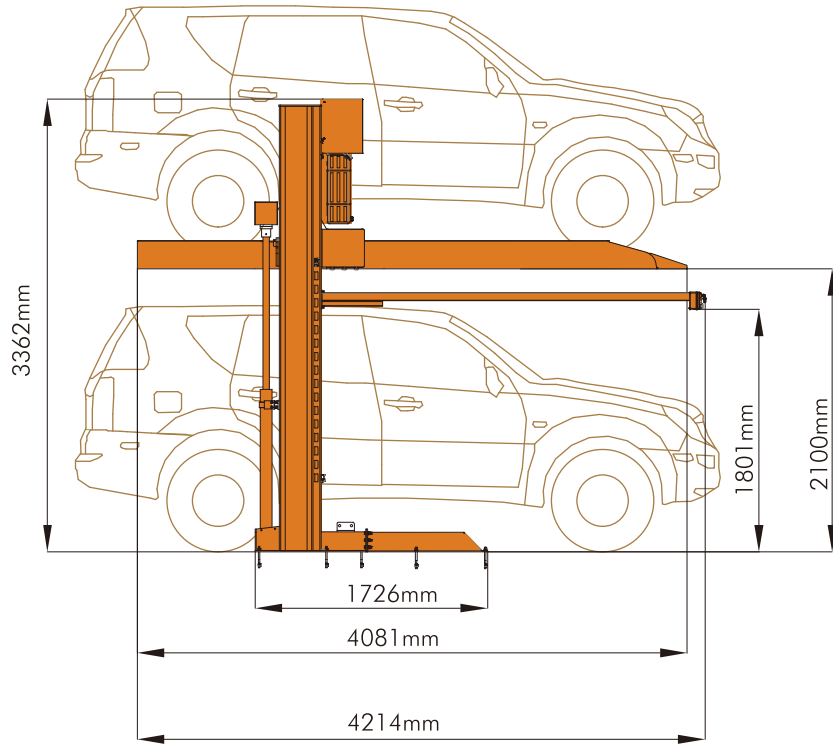

Lifting capacity	2700kg/6000lbs
Lifting height	2100mm/83inches
Usable platform width	2100mm/83inches
Power Unit	3Kw hydraulic pump
Available voltage of power supply	100V-450V, 1 or 3 Phase, 50/60Hz
Operation mode	Key switch
Operation voltage	24V
Safety lock	Dynamic anti-falling lock
Lock release	Electric auto release
Rising/descending speed	<40s
Finishing	Powder coating

